

**LEVERATE TECHNOLOGY
TO IMPROVE PLANT OPERATION**



Truth is ever to be found in the simplicity,
And not in the multiplicity and confusion of things.

Isaac Newtown

So, what is the simple truth in manufacturing

- The goal of any business is making money

- Net Profit
- ROI
- Cash flow

- To measure this goal in manufacturing

- **Throughput**

The rate at which the system generates money through sales

- **Inventory**

All the money that the system has invested in purchasing things which it intends to sell

- **Operational Expense**

All the money the system spends in order to turn inventory into throughput

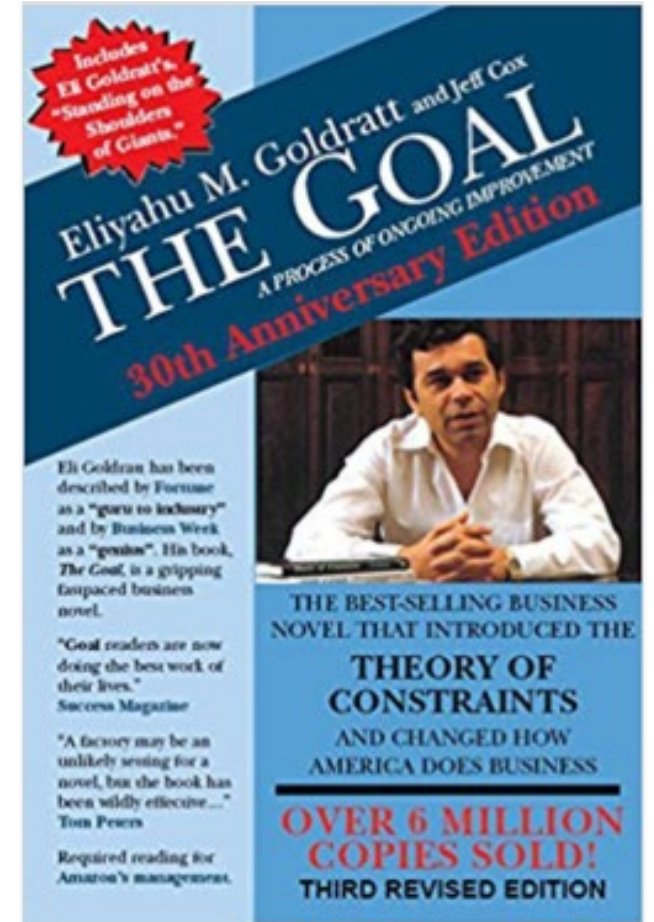

Increase Throughput



Faster Time
to Market

Reduce Inventory



Lower T.C.O.

Reduce Operational Expense



Improve Asset
Utilisation



Enterprise Risk
Management

Where am I going with this

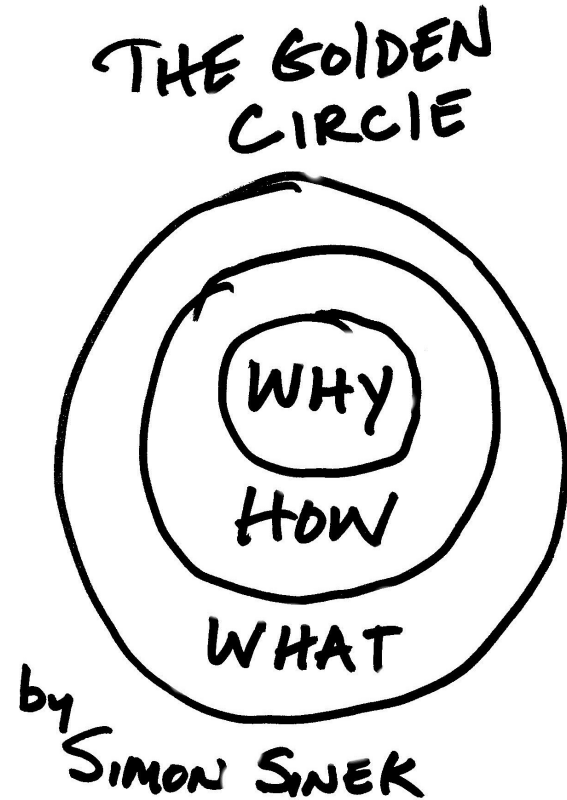

- The **WHY**
 - Business Outcome
- The **HOW**
 - Virtualization
 - Smart Safety
 - Industrial IoT
 - Converge Plant Wide Ethernet
- The **WHAT**
 - Come and talk to us

Virtualization - The Challenge

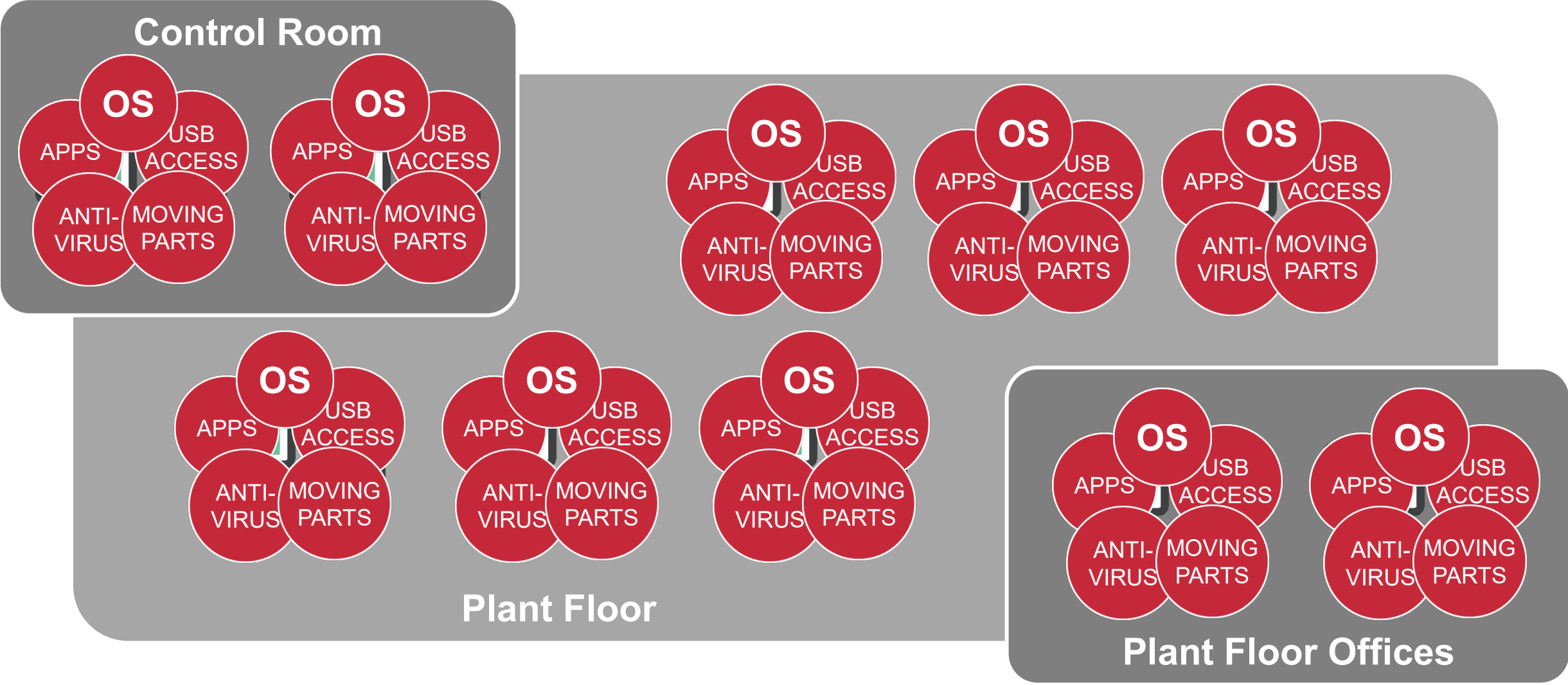

Virtualization – The Solution

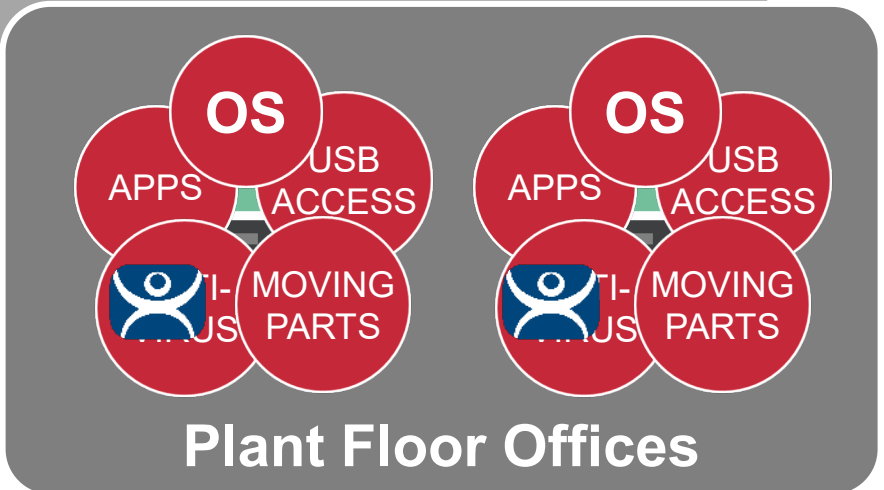
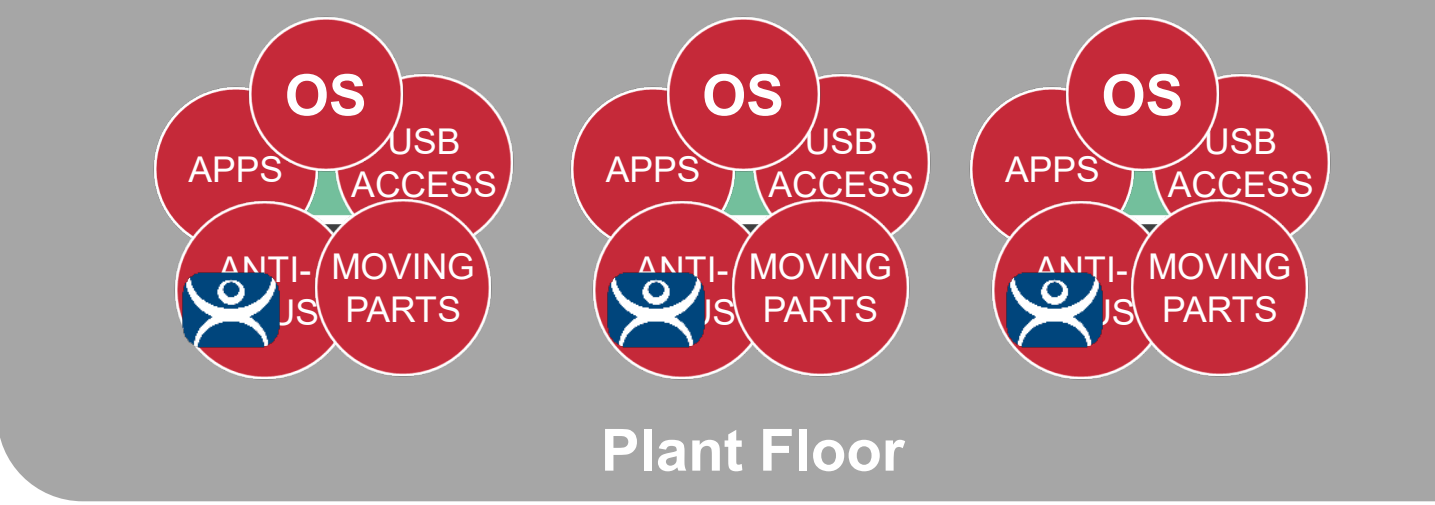
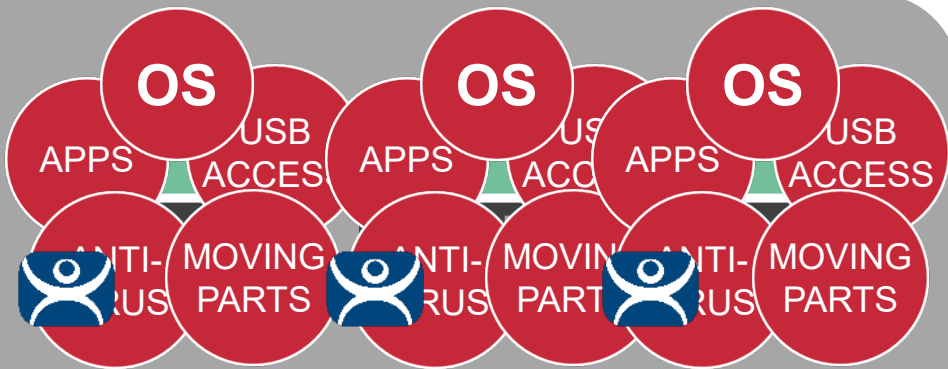
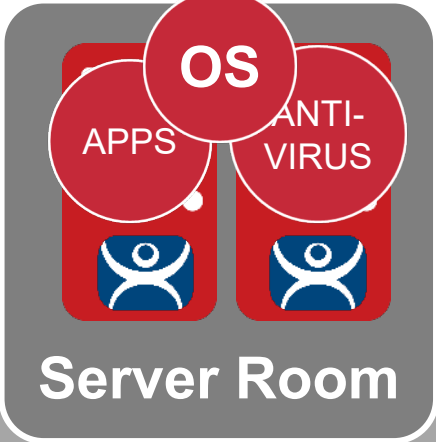
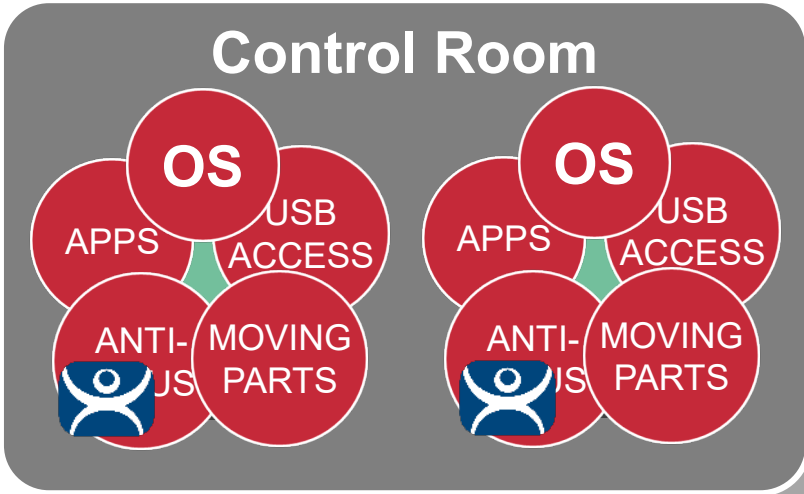

Virtualization

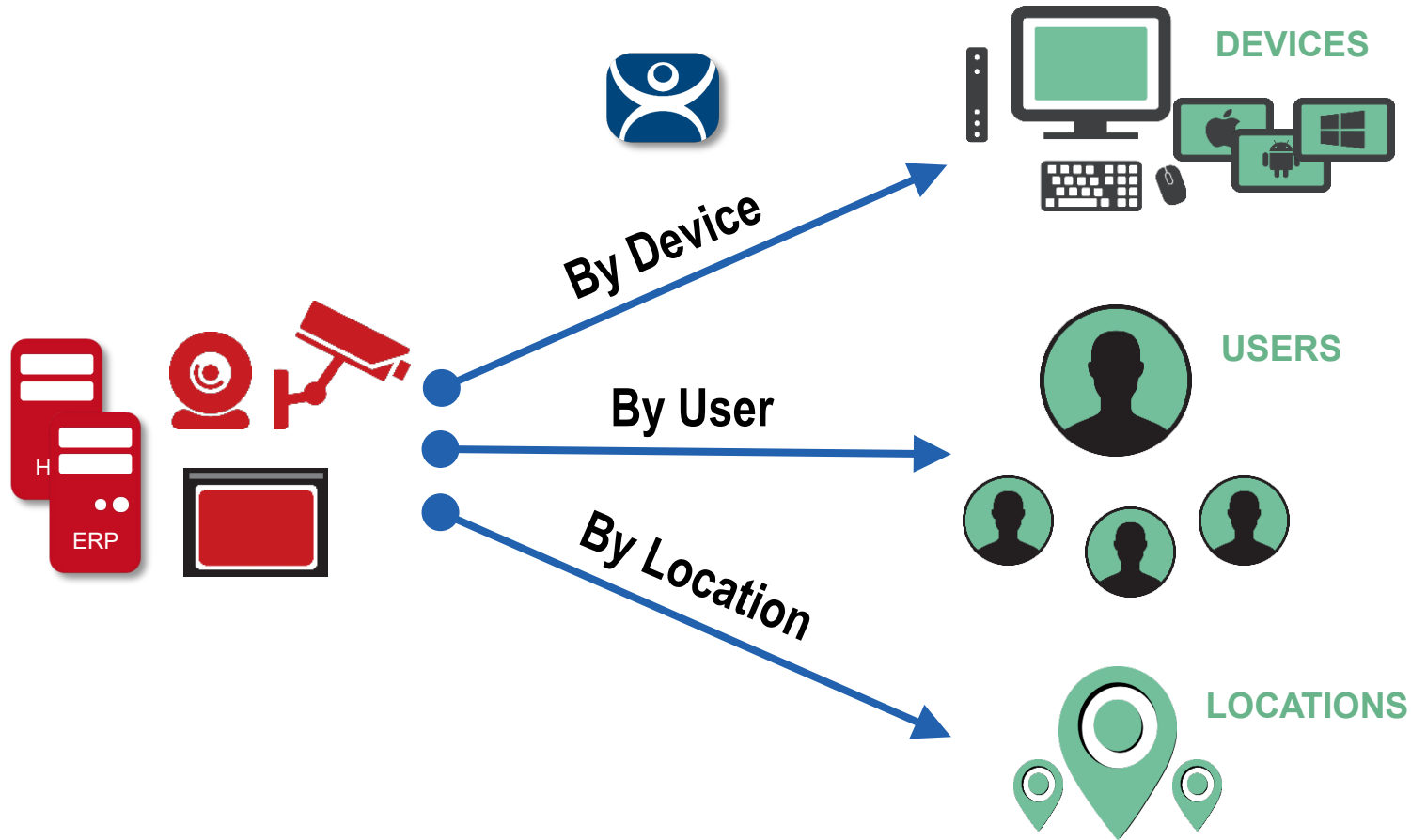

■ The **WHY**

- Lower T.C.O
- Reduce Risk
- Improve Utilisation

■ The **HOW**

- Virtualization

■ The **WHAT**

- Come and talk to us

Smart Safety – The Challenge



- Introduce Downtime
 - Legacy Design Methodology
- Confusing to operate
 - Lack of Diagnostic
- Difficult to Maintain
 - Lack of Flexibility
- Costly to implement
 - Over Engineering
- Longer time to market
 - Difficult to Install

Smart Safety – The Solution



- Introduce Downtime
 - Legacy Design Methodology
 - Tools that help improve design
- Confusing to operate
 - Lack of Diagnostic
 - Smart sensors provide richer Diagnostic Information
- Difficult to Maintain
 - Lack of Flexibility
 - Situational aware system
- Costly to implement
 - Over Engineering
 - Smarter ways of achieving things
- Longer time to market
 - Difficult to Install
 - More efficient data communication

Industrial IoT

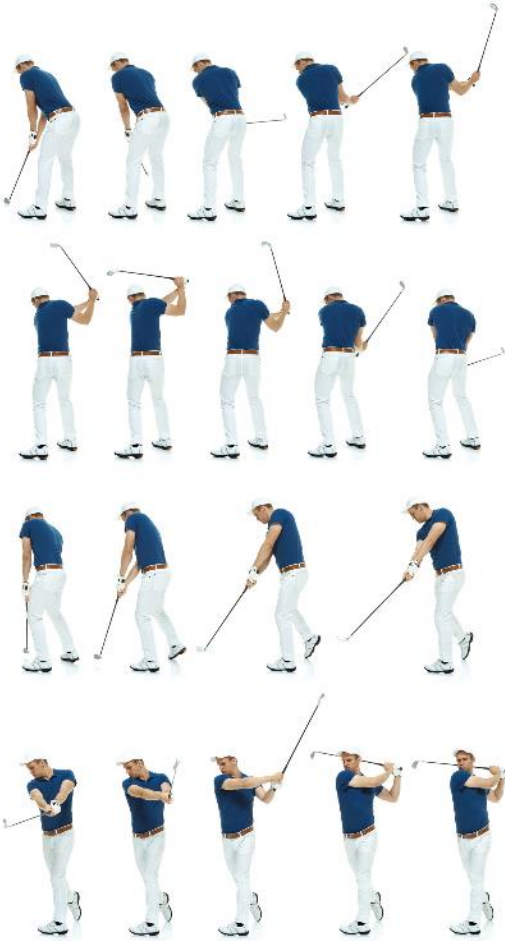

Industrial IoT – The Challenge

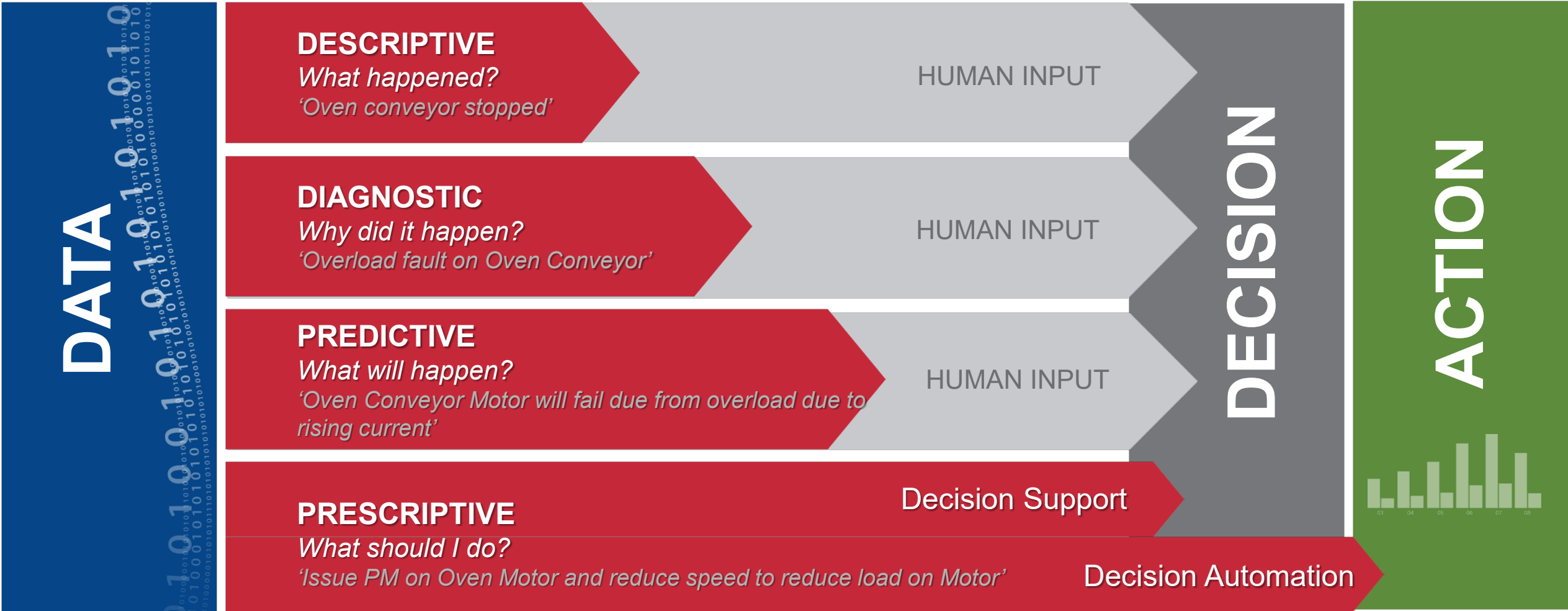

Source: Gartner

Industrial IoT – The Solution



INFORMATION SOLUTIONS CAPABILITIES – Cloud | On-Premise | Edge



SCALABLE EXECUTION SYSTEMS



SCALABLE ANALYTICS



MOBILITY & COLLABORATION



CONNECTED SERVICES

AUTO DISCOVERY

ZERO CONFIG DASHBOARDS

ORCHESTRATION & WORKFLOW

PEOPLE IN THE IIOT

DATA TRANSPORTATION



SENSORS & ACTUATORS



INTELLIGENT MOTOR CONTROL



CONTROLLERS



MOBILE / DISPLAYS



MACHINES & EQUIPMENT



REMOTE ASSETS

CPwE – Reliable and Secure Data Transportation

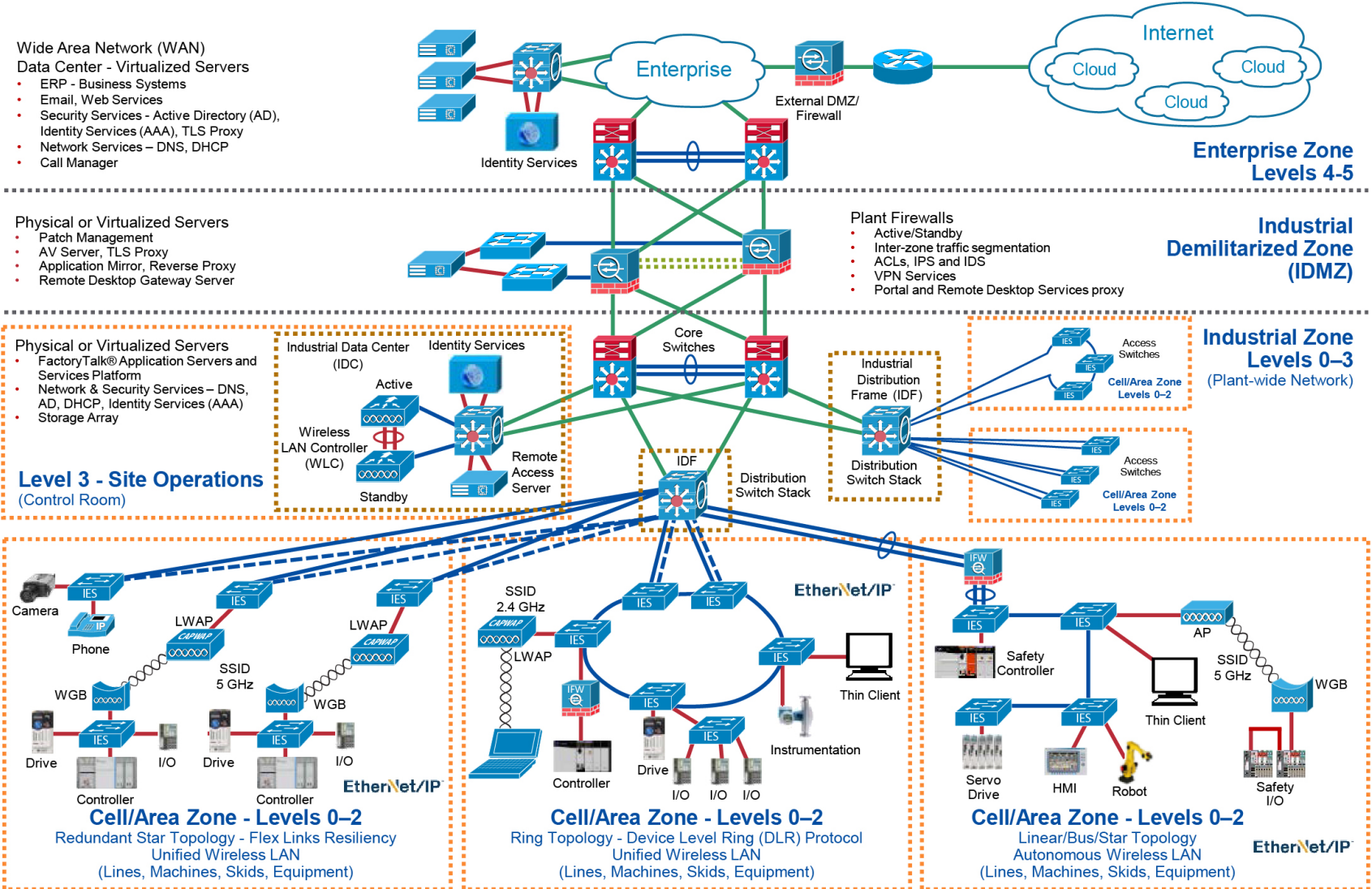

378704

Increase
Throughput



Faster Time
to Market

Reduce
Inventory



Lower T.C.O.

Reduce
Operational Expense



Improve Asset
Utilisation



Enterprise Risk
Management

THE CONNECTED ENTERPRISE

Delivering great business outcomes

QUESTIONS