

# Assessing & incorporating seismic resilience in winery design

---

ADAM WALKER  
WEA 2018, NAPIER

---

# Agenda



## WHAT TO DO ABOUT IT

- Assessment of existing infrastructure
- Options for improvements

## HOW TO AVOID THE SAME MISTAKES

- System specification
- Compliance path

# Assessing & improving the current stock



Winery seismic resilience  
WEA 2018

structex

# Assessing existing infrastructure

## WHY

- Because our insurer requested it
- To get the best return in terms of risk reduction for your capital spend

## HOW

- Engage a structural engineer with experience in tank design
- Discuss your plans for the near future so they can tailor the assessment

# Assessing existing tanks

## LOOK AT COMMON ISSUES

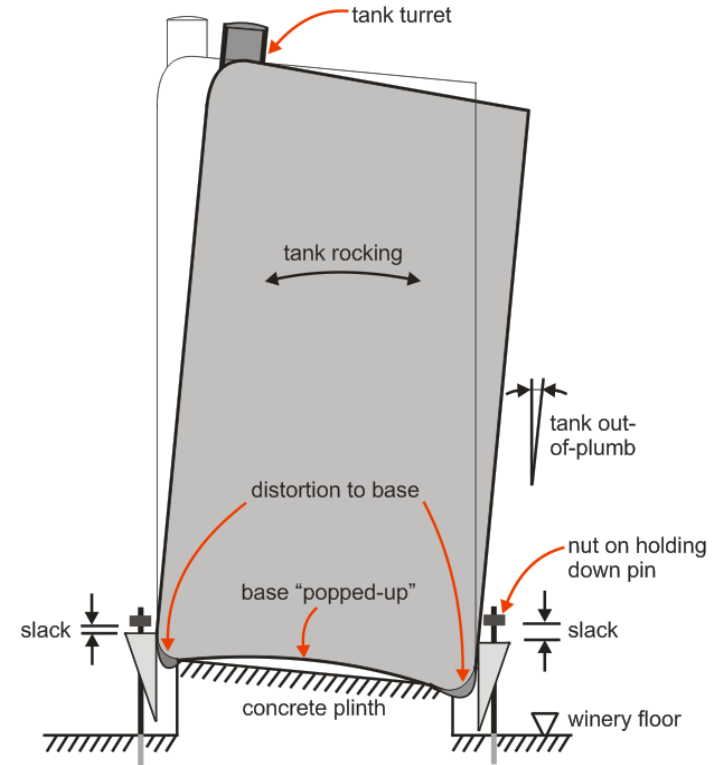

# Assessing existing tanks

## PLINTH TANKS

- Gather together existing drawings
- Site measure of:
  - Tank, particularly wall thickness
  - Slab thickness
  - Anchorage details
- Crunch the numbers

Pay attention to the failure mode, the consequences can be very different

# Assessing existing tanks

## TANKS ON FRAMES

Many different variations



# Assessing existing tanks

## TANKS ON FRAMES

Many different variations

Results in complexity in the assessment, and thus cost

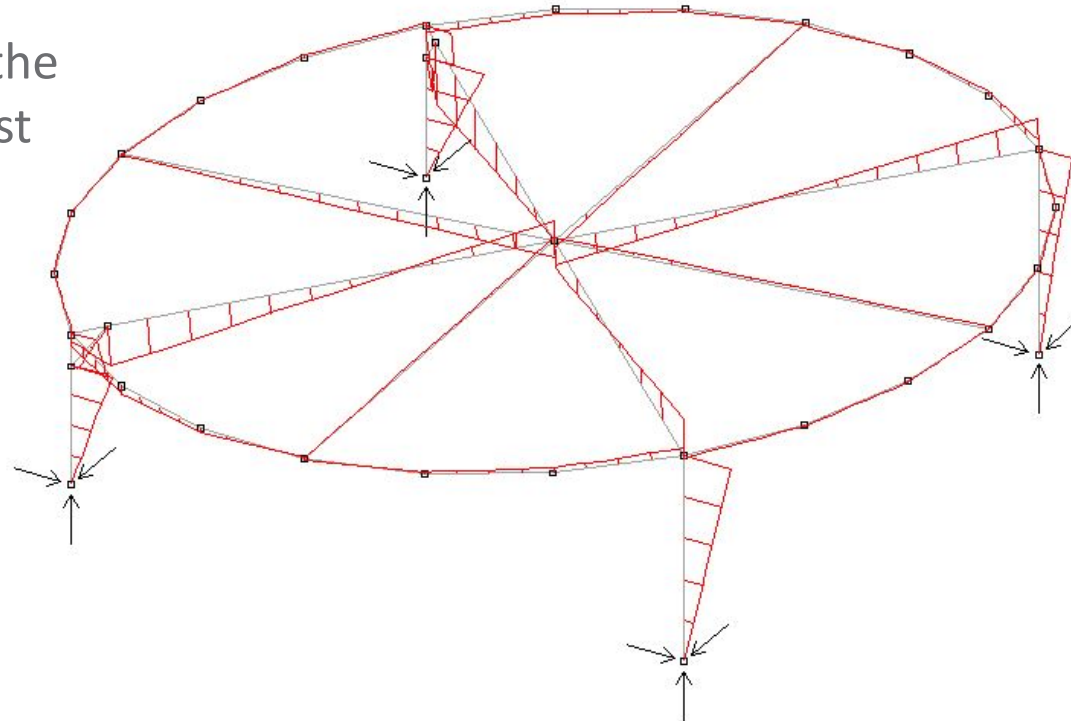

# Assessing existing tanks

## TANKS ON FRAMES

$$\text{DATABASE} + \text{KNOWN ISSUES} + \text{SITE SPECIFIC} = \text{SEISMIC GRADE}$$

# Making Improvements

## WHICH ONES?

- Volume, value, duration, disruption

## TO WHAT SPEC?

- IPENZ Practice Note 19 (pressure vessels) suggests 34% current standard as a minimum
- Earthquake prone building analogy = 67% current standard
- What is the current standard, dictated by Importance Levels, 1 or 2?

# Making Improvements

## DEFINITIONS

Importance Level 1:

- Outbuildings, rural sheds etc
- 50% probability of exceedance over the structures life

Importance Level 2:

- Typical building, home, office
- 10% probability of exceedance over the structures life

	Importance Level 1	Importance Level 2
25 year design life	2% (1 in 50)	0.4% (1 in 250)
50 year design life	1% (1 in 100)	0.2% (1 in 500)

# Making Improvements



# Associated infrastructure

## CATWALKS & SERVICES



# Associated Infrastructure

## BARREL RACKS

We've been lucky so far



# Avoiding the same mistakes in the future



Winery seismic resilience  
WEA 2018

structex

---

# Improving the future

## WHAT CAN GOOD LOOK LIKE

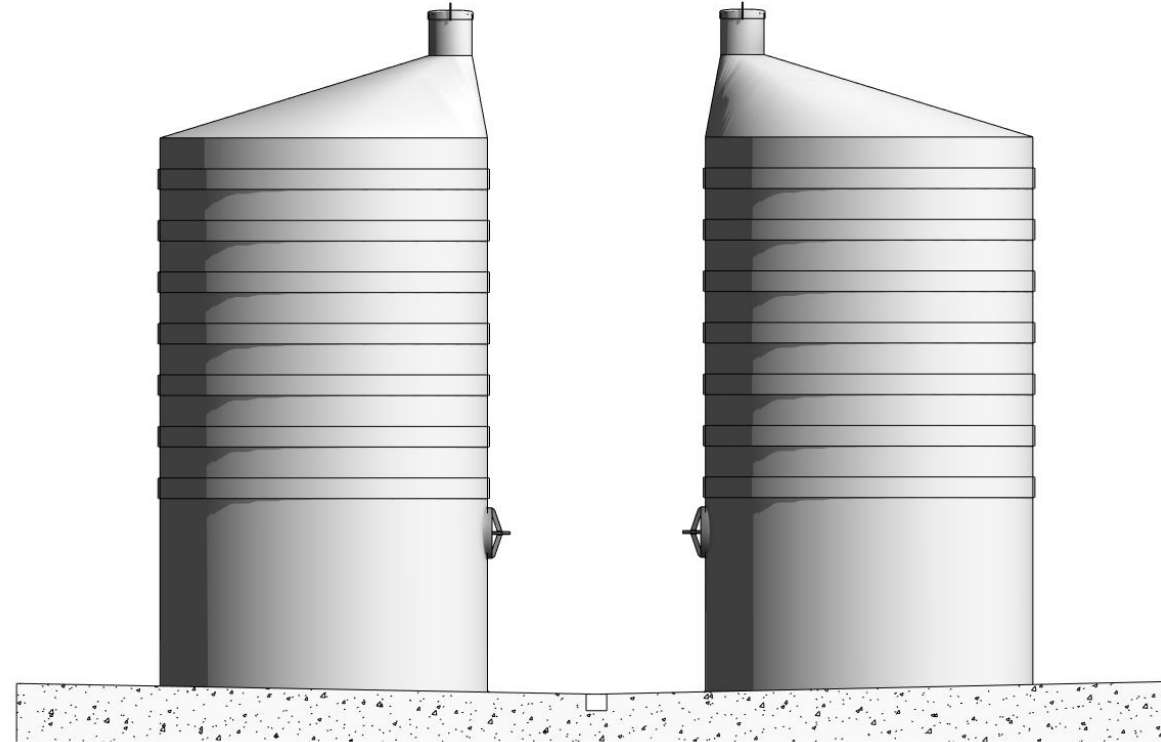

# Improving the future

## WHAT CAN GOOD LOOK LIKE

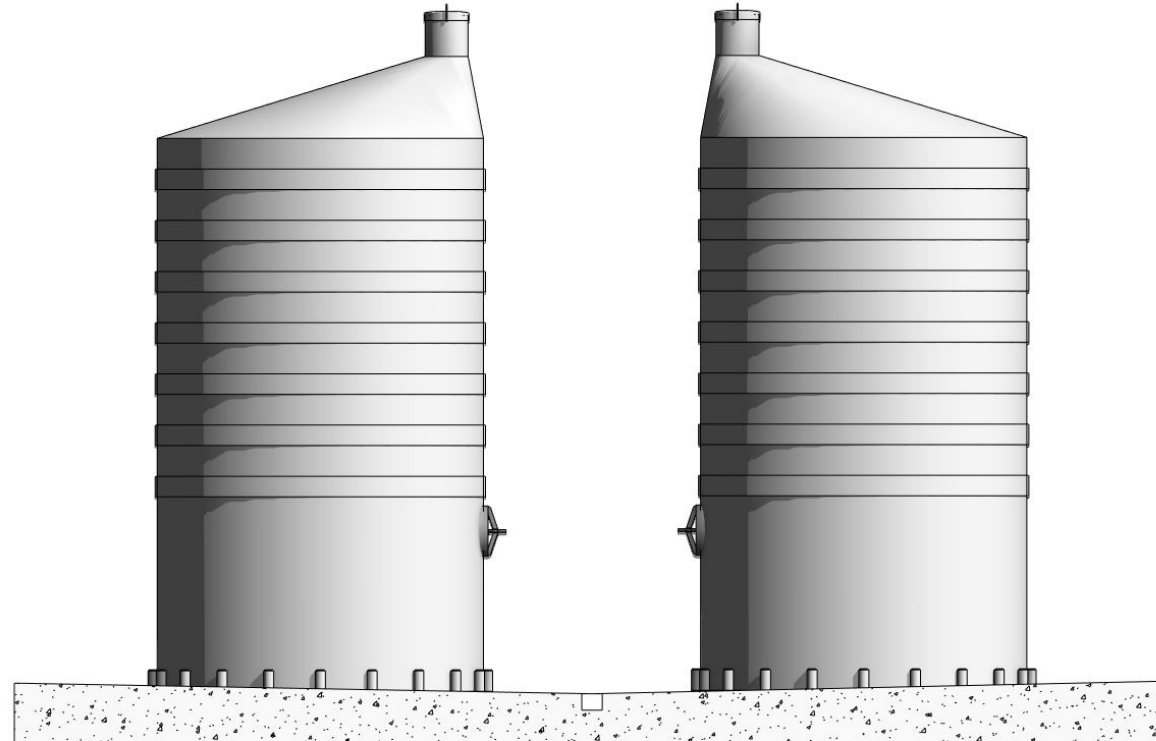

# Improving the future

## WHAT CAN GOOD LOOK LIKE

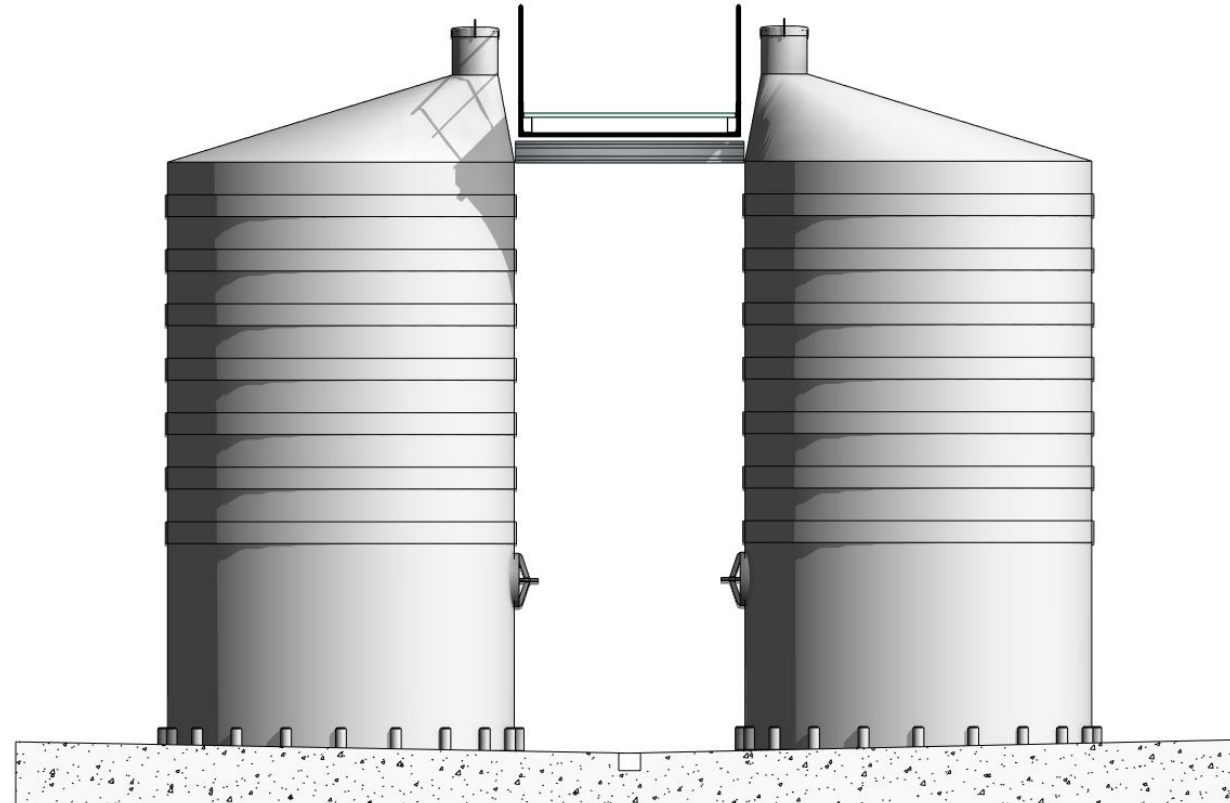

# Improving the future

## WHAT CAN GOOD LOOK LIKE

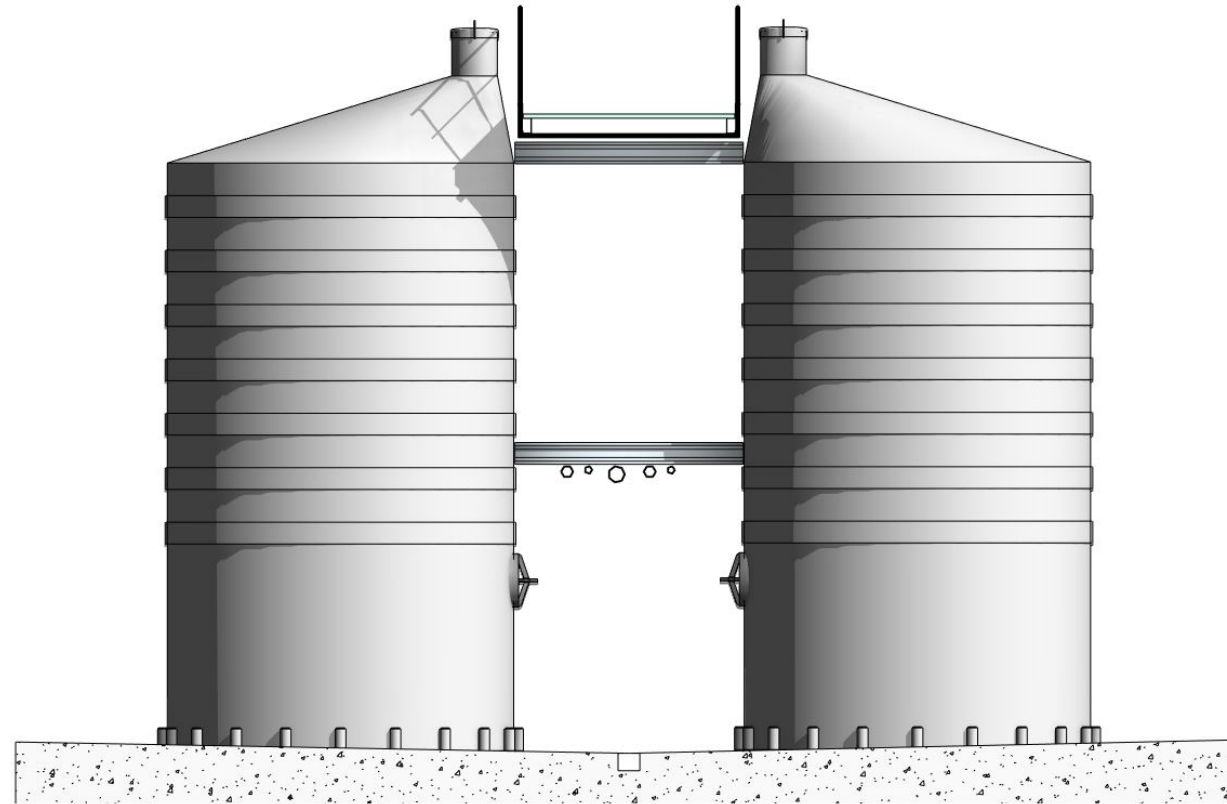

# Improving the future

## WHAT CAN GOOD LOOK LIKE

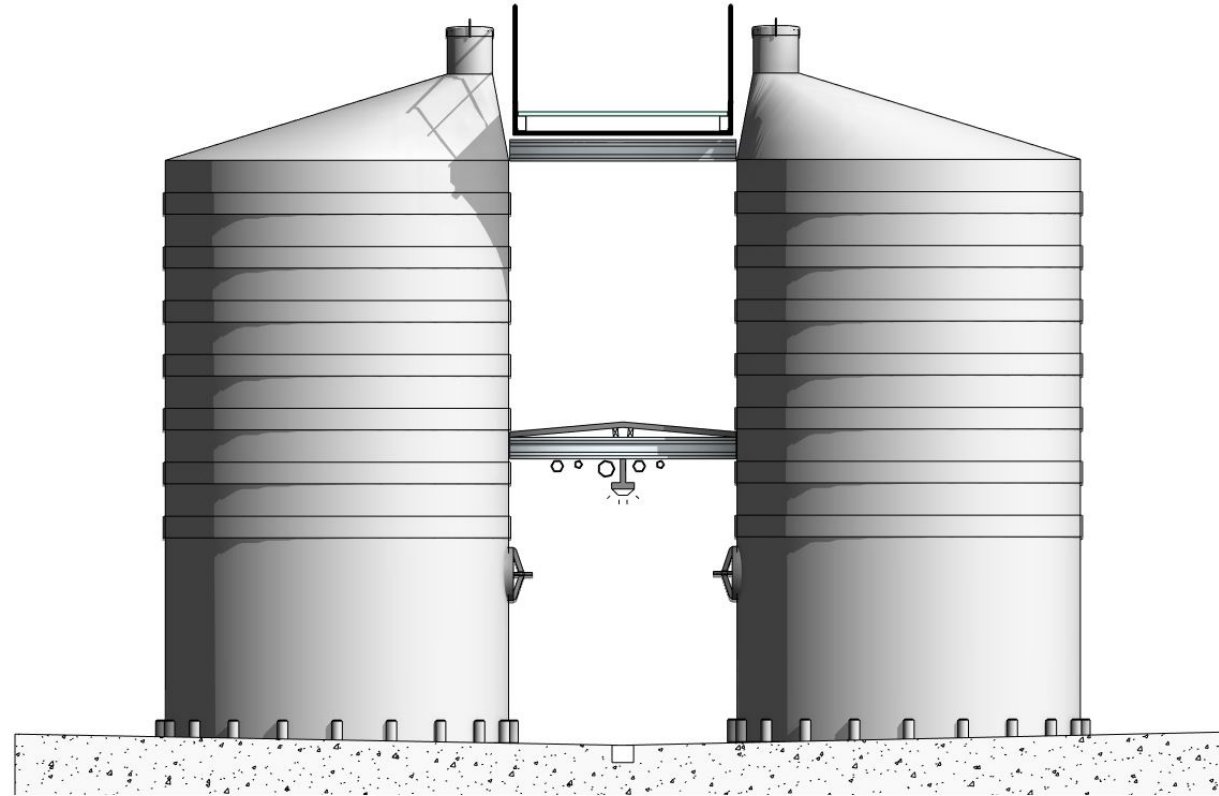

# Improving the future

## WORKING GROUP



# Improving the future

## COMPLIANCE & THE COUNCILS ROLE

- Covered by the Building Act & needs to comply with the Building Code
- No appropriate standard referenced in the Building Code
- Several guidance documents available
- Not automatically exempt under Schedule 1 of the Building Act

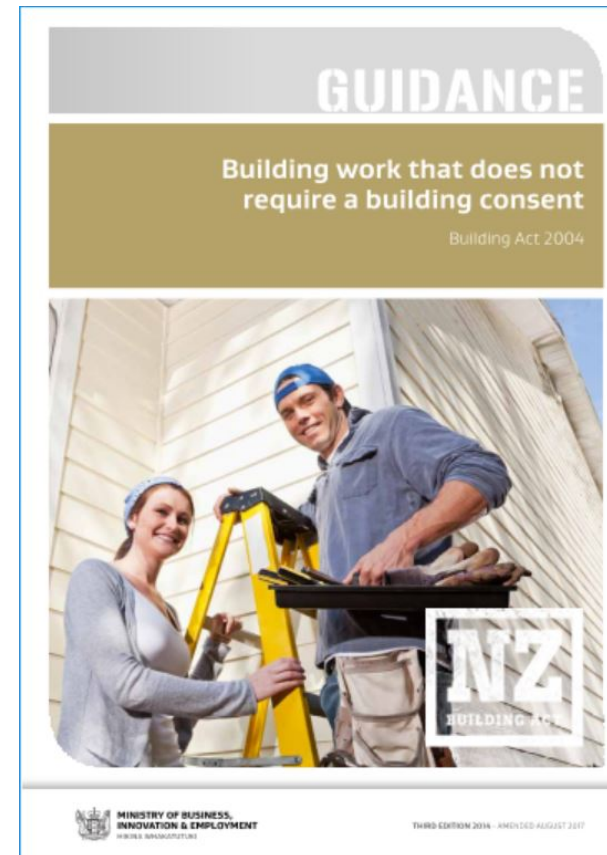

## 23. Tanks and pools

*Building work in connection with a tank or pool and any structure in support of the tank or pool, including any tank or pool that is part of any other building for which a building consent is required, that:*

- (a) does not exceed 500 litres capacity and is supported not more than 4 metres above the supporting ground; or*
- (b) does not exceed 1,000 litres capacity and is supported not more than 3 metres above the supporting ground; or*
- (c) does not exceed 2,000 litres capacity and is supported not more than 2 metres above the supporting ground; or*
- (d) does not exceed 4,000 litres capacity and is supported not more than 1 metre above the supporting ground; or*
- (e) does not exceed 8,000 litres capacity and is supported not more than 0.5 metres above the supporting ground; or*
- (f) does not exceed 16,000 litres capacity and is supported not more than 0.25 metres above the supporting ground; or*
- (g) does not exceed 35,000 litres capacity and is supported directly by ground.*

# Thanks



Winery seismic resilience  
WEA 2018

structex

---